

The Difference Between Structural Silicone Glazing and Butt Joint Glazing

Structural Silicone Glazing continues to be a popular design concept in the architectural community. And, new glass products – including supertints and low-e coated glass – are appropriate for use in structural silicone glazing systems. Architects can combine the pleasing aesthetics and enhanced energy savings of these glass products with the “clean” exterior appearance of structural silicone glazing to satisfy both the design appearance and energy requirements of their buildings.

It is critical, however, to distinguish between structural silicone glazing and its predecessor, “Butt Joint Glazing”. In that regard, the following brief descriptions and sketches of these glazing systems may be helpful.

Structural Silicone Glazing

The glass is supported on all four edges by metal mullions. Retention to the metal mullions is accomplished with an appropriate **structural** silicone bond-joint, rather than with traditional metal retainers and exterior metal trim. The weatherseal between glass lites is accomplished by using **non-structural** silicone. Structural Glazing Systems can be designed to accommodate either monolithic glass or insulating glass units. The glass can be structurally glazed with silicone on one or more edges, with traditional retention on the remaining edges. Typical structural silicone glazing includes the 2-side or “*ribbon window*” appearance (Sketch 1), or 4-side to create a totally flush glazed appearance (Sketch 2). Sketches 3 and 4 are typical details at the vertical and horizontal mullions.

Structural Silicone Glazing requires that appropriate consideration be given to a number of critical design elements. Some, but not all of these include:

- ✓ Use of a proper structural sealant.
- ✓ Joint size must be designed for the specified design load; the sealant supplier should be consulted for guidance and support.
- ✓ The structural silicone sealant must be tested for compatibility with all materials to which it must adhere on a project specific basis.
- ✓ The structural silicone sealant must be tested for compatibility with all other sealants and materials that it may contact.
- ✓ Recommended surface preparation and sealant application procedures must be followed.

- ✓ The structural sealant supplier's specified recommendations for appropriate field glazing must be followed.
- ✓ Insulating glass units must be fabricated with a structural silicone secondary seal that is appropriately designed to resist specified loads.
- ✓ Because glass edges are exposed, some type of edge treatment may be required for aesthetic purposes.

Sketch 1: 2-Side Structural Silicone Glazing

Glass structurally adhered to metal back-up vertical mullion and two sides captured in horizontal mullion pocket.

Glazing Captured in Metal Frame @ Head and Sill in this example

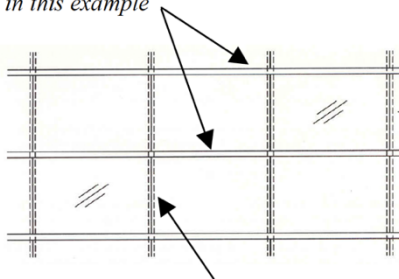

Structural Silicone Glazed to Vertical Mullions

Sketch 2: 4-Side Structural Silicone Glazing

Glass structurally adhered to both vertical and horizontal mullions.

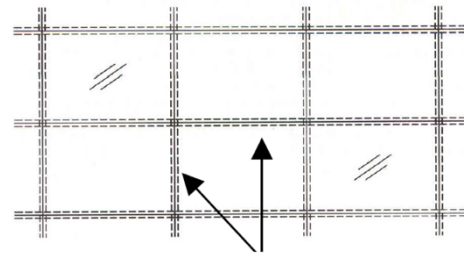

Structural silicone glazed to vertical & horizontal mullions

Sketch 3: Typical Vertical Mullion Detail

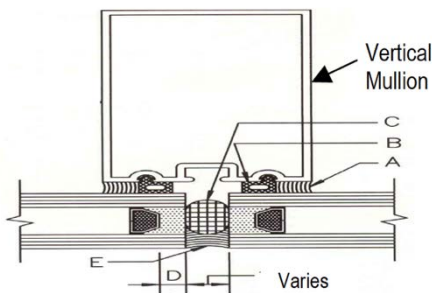

Legend

- A = Structural Silicone
- B = Compatible Spacer
- C = Compatible Backer Rod
- D = I.G. Structural Silicone Depth
- E = Silicone Weather Seal
- F = Setting Blocks

Sketch 4: Typical Horizontal Mullion Detail

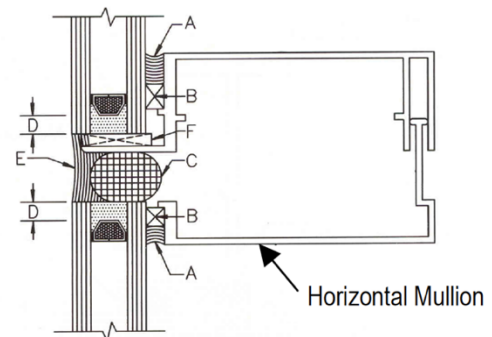

Butt Joint Glazing

In Butt Joint Glazing, the glass is supported on only two edges. Glass lites are retained at the head and sill in a traditional rabbeted glazing system, with the application of a silicone sealant weather-seal between the unsupported edges of adjacent glass lites. A key distinction is that the sealant acts as a weather seal only and, absent the interior supporting mullions, cannot be considered to be structural. Under load, each glass lite behaves as a simply supported beam (See Sketch 5).

While Butt Joint Glazing may appear aesthetically similar to 2-side Structural Silicone Glazing, its performance under loading is drastically different. For any specified probability of glass breakage, the corresponding load will be much less for the butt joint glazed system than for the 2-side structural silicone system. And, the center deflection of the glass will be much greater.

Due to the potentially excessive deflections that can occur, insulating glass units should not be used in butt joint glazing systems and glass fabricators will not typically warrant insulating glass units used in these applications. Since butt joint glazing systems are only 2-side support, glass thickness of ½” or more is required to meet even modest load requirements. This limits the use of butt-joint glazing systems to store fronts, interior office partitions, and other applications where maximum view is desired and the specified load criteria is relatively low.

Sketch 5: Butt Joint Glazing Detail

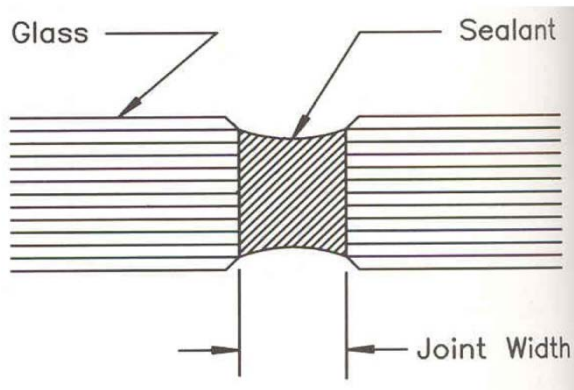

The Difference Between Structural Silicone Glazing and Butt Joint Glazing

HISTORY TABLE		
ITEM	DATE	DESCRIPTION
Originated Document	2/26/03	

This document is intended to inform and assist the reader in the application, use, and maintenance of Vitro Architectural Glass products. Actual performance and results can vary depending on the circumstances. Vitro makes no warranty or guarantee as to the results to be obtained from the use of all or any portion of the information provided herein, and hereby disclaims any liability for personal injury, property damage, product insufficiency, or any other damages of any kind or nature arising from the reader's use of the information contained herein.